

# Simulating the Charging of Dust Particles in the Sheath of a Plasma

**Evelyn Guay**  
**Dr. Lorin Matthews**



# Overview

- Dusty plasma
- Simulation design
- Dust charging

# Background on Dusty Plasma

- PK-4 Experiments
- Ground Experiments
- Simulations

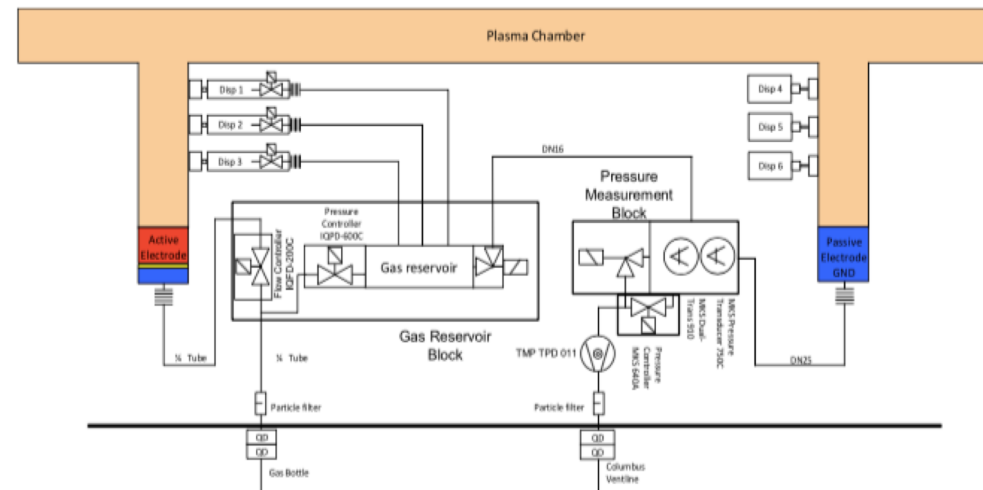
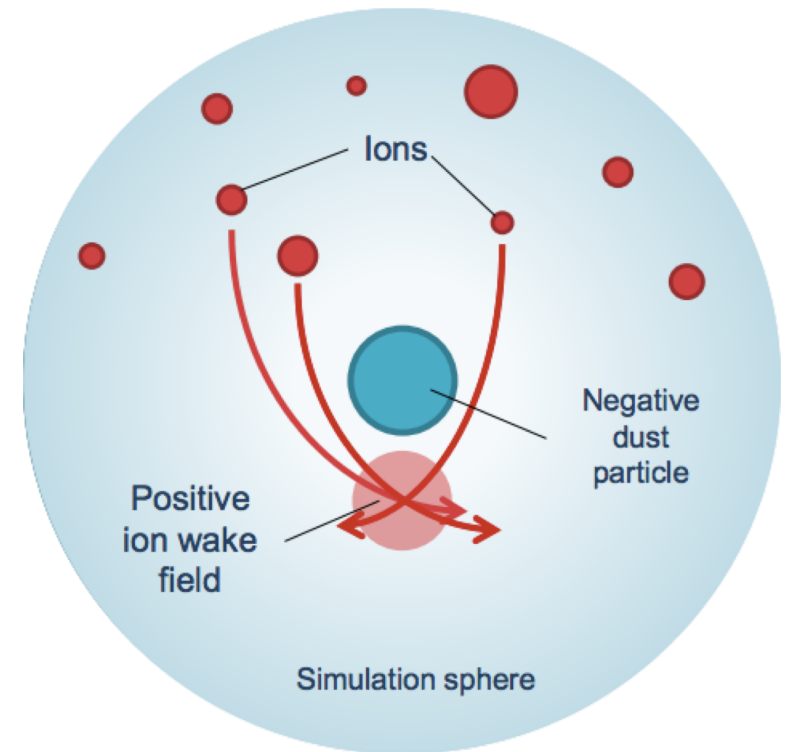
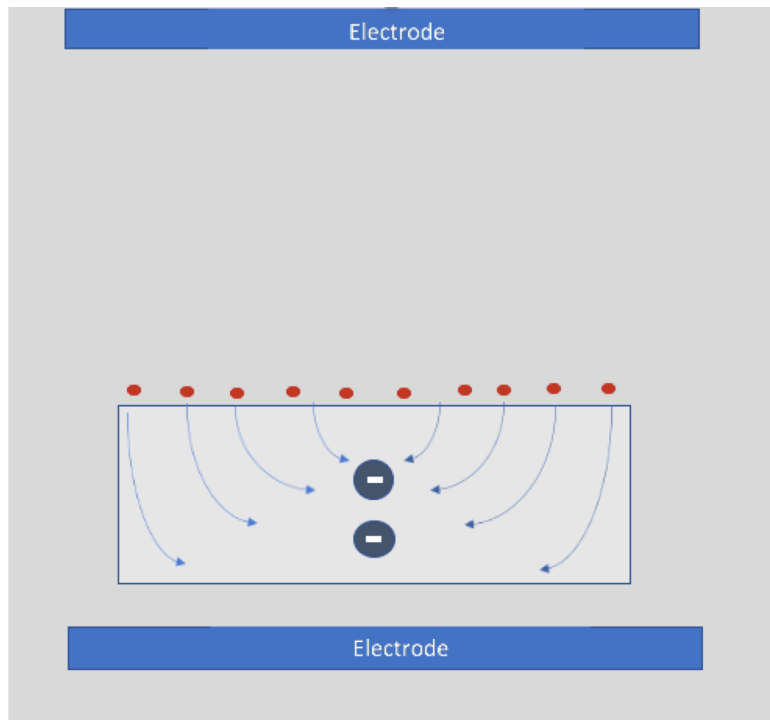

FIG. 1. Scheme of PK-4 vacuum and gas supply system. Plasma chamber contains the main experimental volume, where appropriate vacuum condition as well as working pressure regulation must be provided. Columbus ventline is used as a prevacuum pumping stage and Pfeiffer Vacuum TPD 011 turbomolecular pump produces high vacuum. The plasma chamber is filled with the working gas via the Bronkhorst IQFD-200C flow controller, whereas the pressure is controlled by the MKS 640A pressure controller. Gas reservoir, pressurized with the Bronkhorst IQPD-600C high pressure controller, contains gas for the operation of gas-jet dispensers. The bold horizontal line behind the particle filters designates the wall of the hermetically sealed experiment container (see Section III A). Gas and forevacuum are supplied to the IBP via the feedthroughs.

# Dust Charging

- Negatively charged by electrons
- Ion-Dust collisions



# Factors Affecting the Charge

- Mach Number = ion velocity/sound speed
- Ion Concentration
- Electric Field
- Ion Current
- Time step

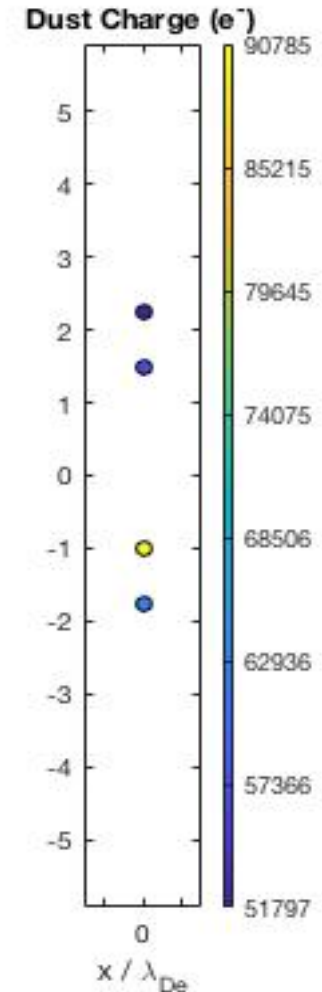

# Mach Number

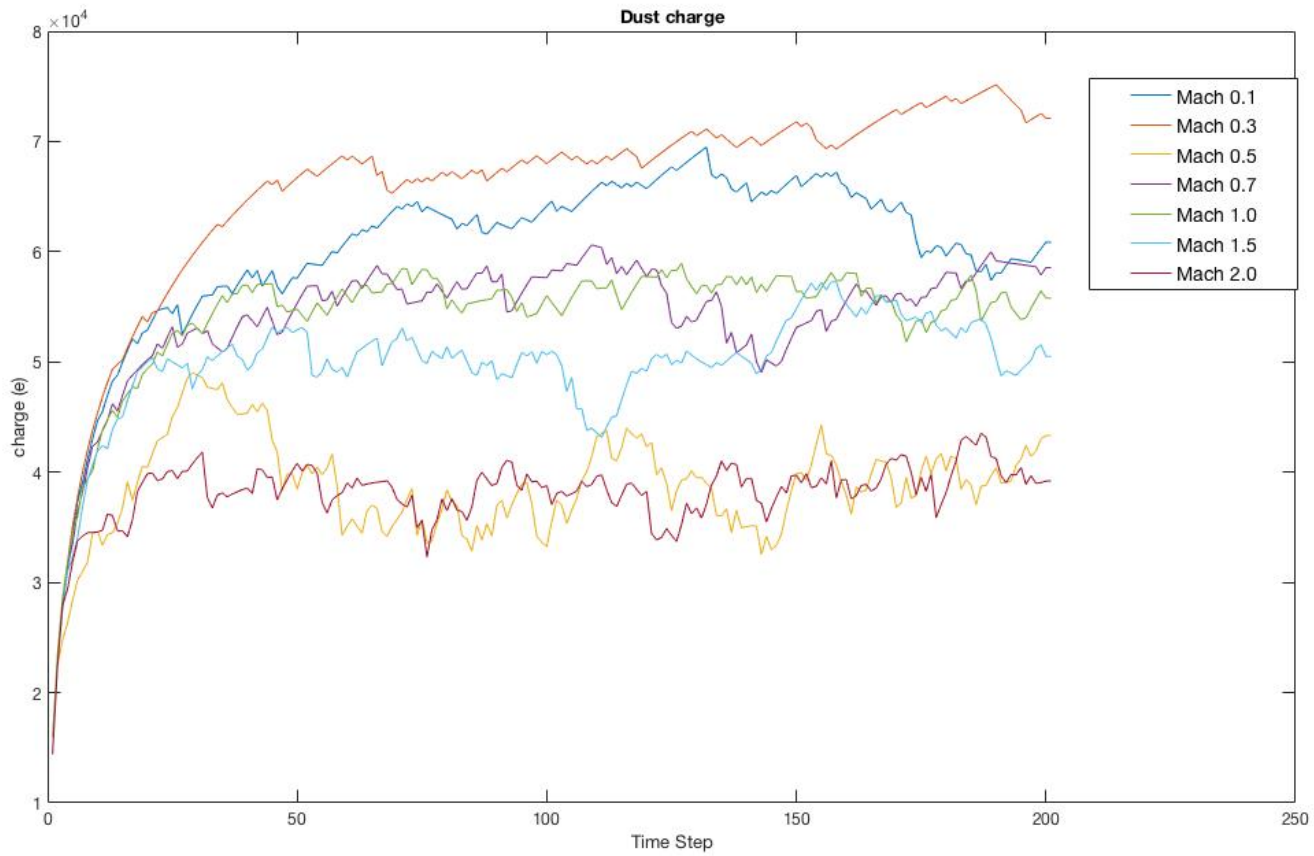

# Ion Concentration

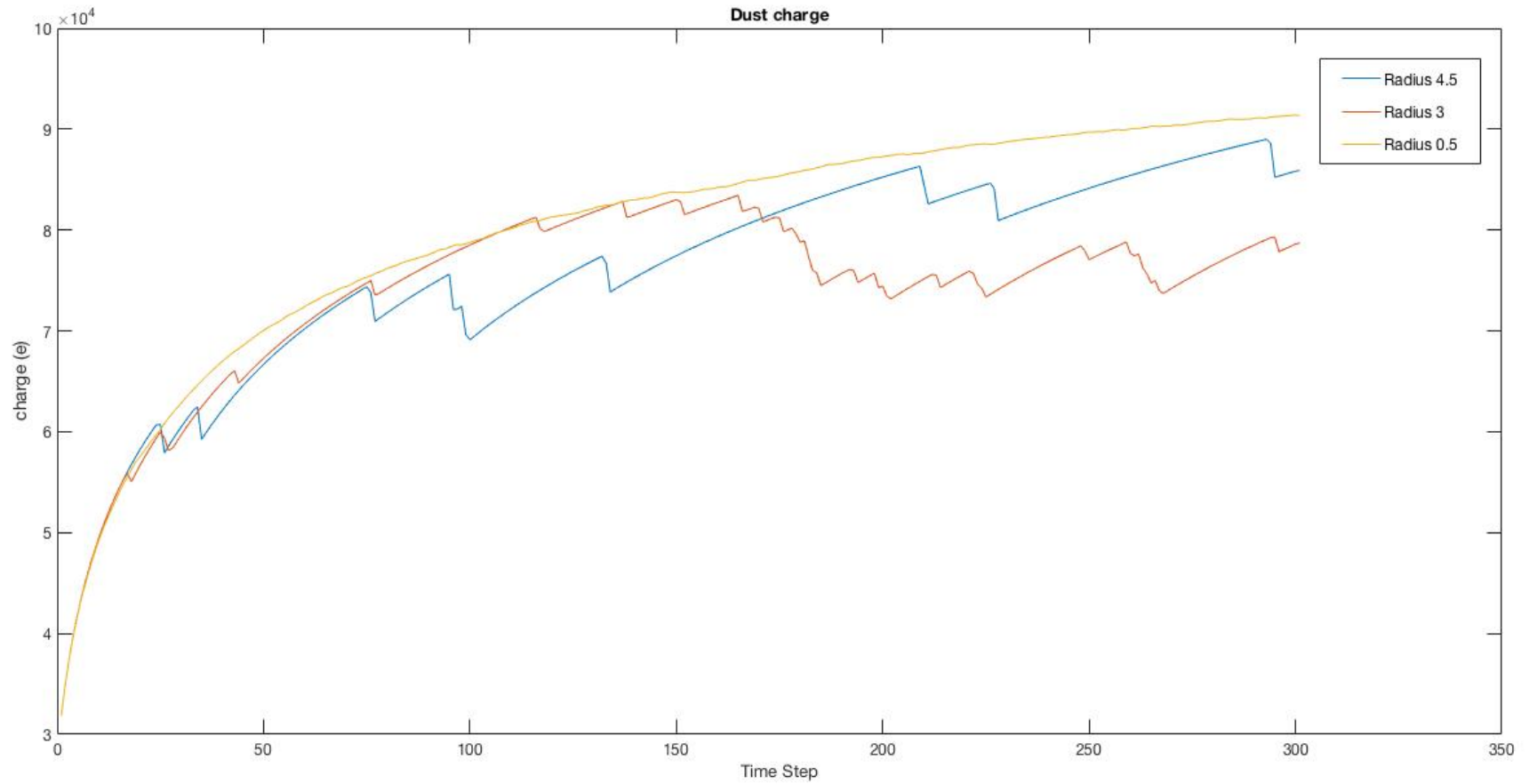

# Electric Field

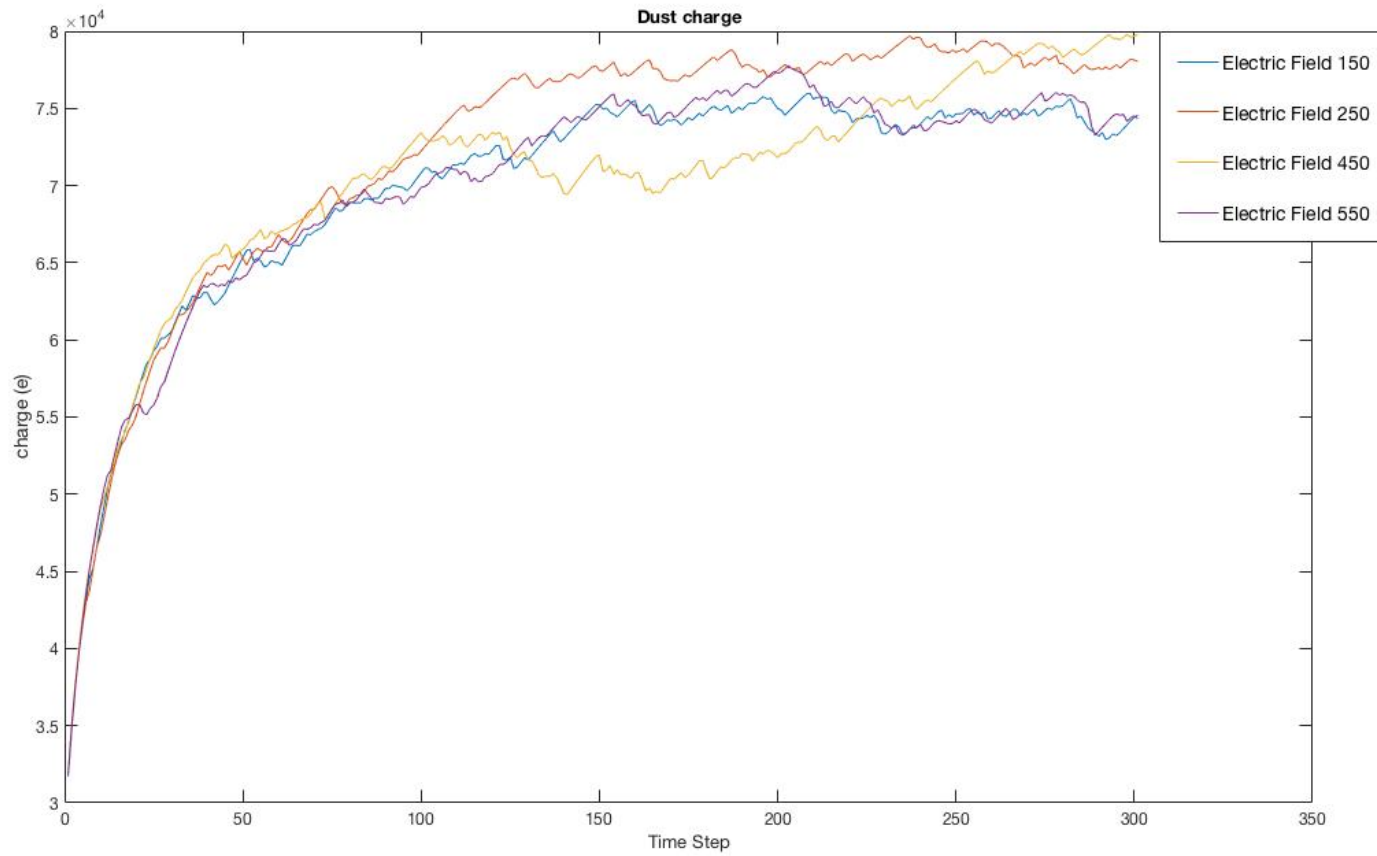



# Problems with the Charge

- Large negative charges

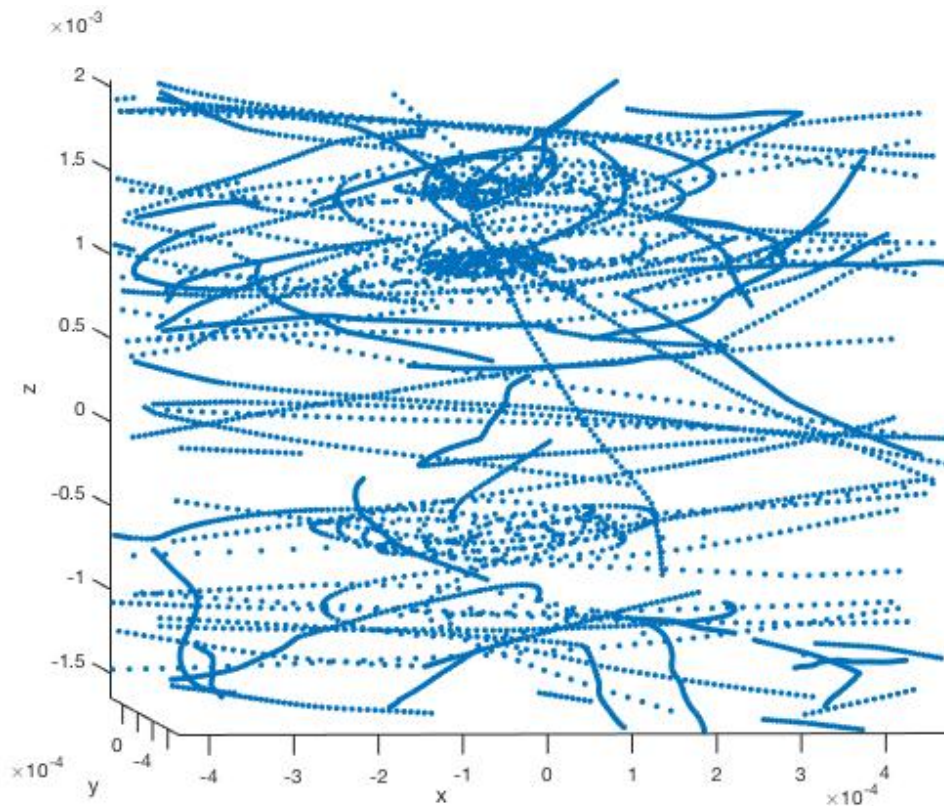

# Timestep

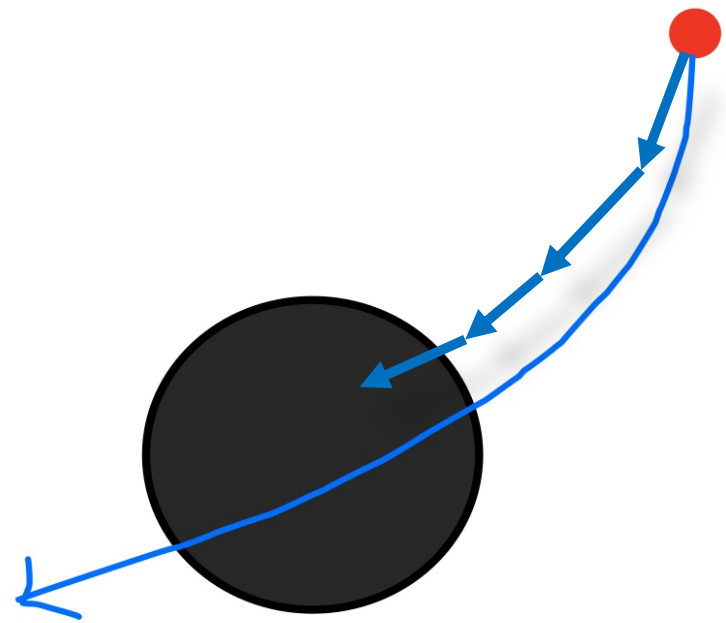
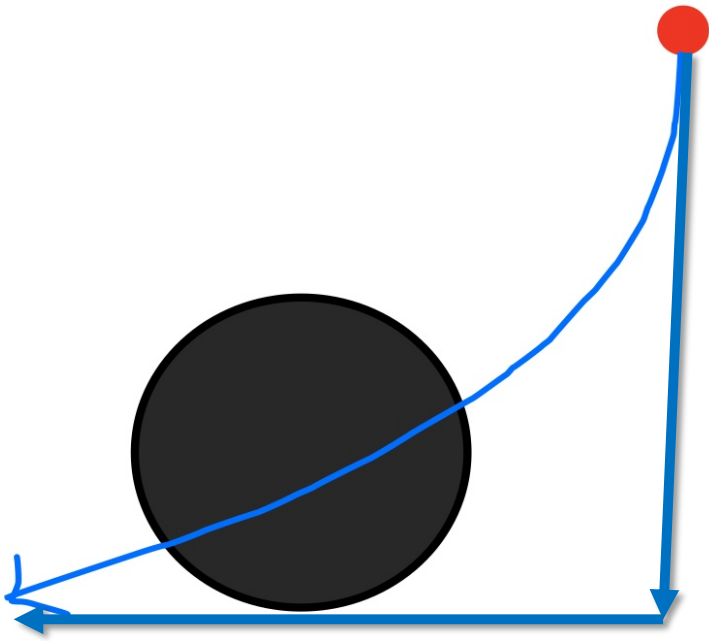

# Leap Frog Adaptation

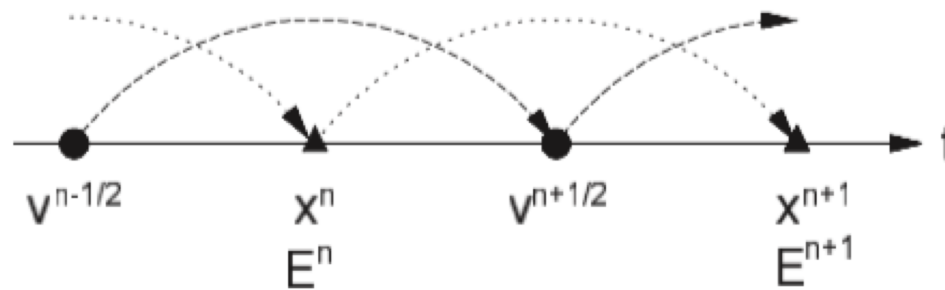

**Figure 2.** Schematic of the leapfrog scheme. Not shown are charge density  $\rho$  and potential  $\Phi$ , which are defined at the same temporal locations as position  $x$  of the particles. Also not shown are current density  $J$  and magnetic field  $B$ , which are defined at the temporal locations of particle velocity  $v$ .

# Further Research

- Dust charge due to ion – neutral collisions
- Continuing to refine parameters



# Acknowledgements



- NSF Grant I414523
- NSF Grant I707215
- NSF Grant I571701
- Dr. Matthews and Dr. Hyde
- Center for Astrophysics, Space Physics, and Engineering Research, Baylor University

